

PE83340

Military Operating Temperature Range

3.0 GHz Integer-N PLL for Low Phase Noise Applications

Product Description

Peregrine's PE83340 is a high performance integer-N PLL capable of frequency synthesis up to 3.0 GHz. The superior phase noise performance of the PE83340 makes it ideal for applications such as wireless local loop basestations, LMDS systems and other demanding terrestrial systems.

The PE83340 features a 10/11 dual modulus prescaler, counters and a phase comparator as shown in Figure 1. Counter values are programmable through a three wire serial interface.

The PE83340 is optimized for stringent military environments. Fabricated in Peregrine's patented UTSi[®] (Ultra Thin Silicon) CMOS technology, the PE83340 offers excellent RF performance with the economy and integration of conventional CMOS.

Features

- 3.0 GHz operation
- $\div 10/11$ dual modulus prescaler
- Internal phase detector
- Serial programmable
- Low power — 20 mA at 3 V
- Ultra-low phase noise
- Available in 20-lead TSSOP

Figure 1. Block Diagram

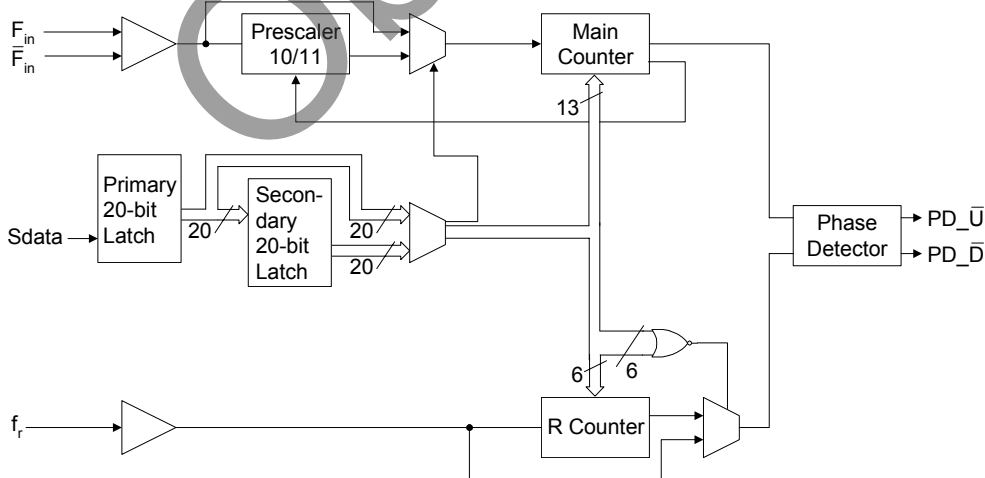
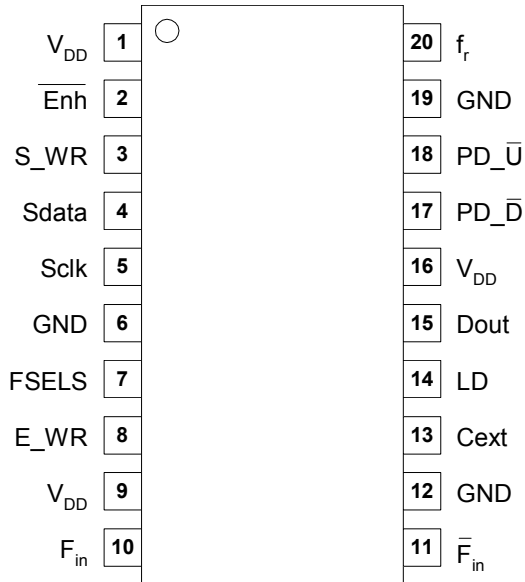

Figure 2. Pin Configuration

Table 1. Pin Descriptions

Pin No.	Pin Name	Type	Description
1	V _{DD}	(Note 1)	Power supply input. Input may range from 2.85 V to 3.15 V. Bypassing required.
2	Enh	Input	Enhancement mode. When asserted low ("0"), enhancement register bits are functional. Internal 70 kΩ pull-up resistor.
3	S_WR	Input	Serial load enable input. While S_WR is "low", Sdata can be serially clocked. Primary register data are transferred to the secondary register on S_WR rising edge.
4	Sdata	Input	Binary serial data input. Input data entered MSB first.
5	Sclk	Input	Serial clock input. Sdata is clocked serially into the 20-bit primary register (E_WR "low") or the 8-bit enhancement register (E_WR "high") on the rising edge of Sclk.
6	GND		Ground.
7	FSELS	Input	Selects contents of primary register (FSELS=1) or secondary register (FSELS=0) for programming of internal counters. Internal 70 kΩ pull-down resistor.
8	E_WR	Input	Enhancement register write enable. While E_WR is "high", Sdata can be serially clocked into the enhancement register on the rising edge of Sclk. Internal 70 kΩ pull-down resistor.
9	V _{DD}	(Note 1)	Same as pin 1.
10	F _{in}	Input	Prescaler input from the VCO. Max frequency input is 3.0 GHz.
11	Fin	Input	Prescaler complementary input. A bypass capacitor should be placed as close as possible to this pin and be connected in series with a 50 Ω resistor to the ground plane.
12	GND		Ground.
13	Cext	Output	Logical "NAND" of PD_U and PD_D terminated through an on chip, 2 kΩ series resistor. Connecting Cext to an external capacitor will low pass filter the input to the inverting amplifier used for driving LD.
14	LD	Output	Lock detect is an open drain logical inversion of CEXT. When the loop is in lock, LD is high impedance, otherwise LD is a logic low ("0").
15	Dout	Output	Data out function, Dout, enabled in enhancement mode.
16	V _{DD}	(Note 1)	Same as pin 1.

Pin No.	Pin Name	Type	Description
17	PD_D	Output	PD_D pulses down when f_p leads f_c .
18	PD_U	Output	PD_U pulses down when f_c leads f_p .
19	GND		Ground.
20	f_r	Input	Reference frequency input.

Note 1: V_{DD} pins 1, 9, and 16 are connected by diodes and must be supplied with the same positive voltage level.

Table 2. Absolute Maximum Ratings

Symbol	Parameter/Conditions	Min	Max	Units
V_{DD}	Supply voltage	-0.3	4.0	V
V_i	Voltage on any input	-0.3	$V_{DD} + 0.3$	V
I_i	DC into any input	-10	+10	mA
I_o	DC into any output	-10	+10	mA
T_{stg}	Storage temperature range	-65	150	°C

Electrostatic Discharge (ESD) Precautions

When handling this *UTSi*[®] device, observe the same precautions that you would use with other ESD-sensitive devices. Although this device contains circuitry to protect it from damage due to ESD, precautions should be taken to avoid exceeding the rating specified in Table 4.

Latch-Up Avoidance

Unlike conventional CMOS devices, *UTSi*[®] CMOS devices are immune to latch-up.

Table 3. Operating Ratings

Symbol	Parameter/Conditions	Min	Max	Units
V_{DD}	Supply voltage	2.85	3.15	V
T_A	Operating ambient temperature range	-55	125	°C

Table 4. ESD Ratings

Symbol	Parameter/Conditions	Level	Units
V_{ESD}	ESD voltage human body model (Note 1)	1000	V

Note 1: Periodically sampled, not 100% tested. Tested per MIL-STD-883, M3015 C2

Table 5. DC Characteristics
 $V_{DD} = 3.0\text{ V}$, $-55^\circ\text{ C} < T_A < 125^\circ\text{ C}$, unless otherwise specified

Symbol	Parameter	Conditions	Min	Typ	Max	Units
I_{DD}	Operational supply current; Prescaler enabled	$V_{DD} = 2.85\text{ to }3.15\text{ V}$		20	35	mA
Digital Inputs: S_WR, Sdata, Sclk						
V_{IH}	High level input voltage	$V_{DD} = 2.85\text{ to }3.15\text{ V}$	$0.7 \times V_{DD}$			V
V_{IL}	Low level input voltage	$V_{DD} = 2.85\text{ to }3.15\text{ V}$			$0.3 \times V_{DD}$	V
I_{IH}	High level input current	$V_{IH} = V_{DD} = 3.15\text{ V}$			+1	μA
I_{IL}	Low level input current	$V_{IL} = 0, V_{DD} = 3.15\text{ V}$	-1			μA
Digital inputs: Enh (contains a 70 kΩ pull-up resistor)						
V_{IH}	High level input voltage	$V_{DD} = 2.85\text{ to }3.15\text{ V}$	$0.7 \times V_{DD}$			V
V_{IL}	Low level input voltage	$V_{DD} = 2.85\text{ to }3.15\text{ V}$			$0.3 \times V_{DD}$	V
I_{IH}	High level input current	$V_{IH} = V_{DD} = 3.15\text{ V}$			+1	μA
I_{IL}	Low level input current	$V_{IL} = 0, V_{DD} = 3.15\text{ V}$	-100			μA
Digital inputs: FSELS, E_WR (contains a 70 kΩ pull-down resistor)						
V_{IH}	High level input voltage	$V_{DD} = 2.85\text{ to }3.15\text{ V}$	$0.7 \times V_{DD}$			V
V_{IL}	Low level input voltage	$V_{DD} = 2.85\text{ to }3.15\text{ V}$			$0.3 \times V_{DD}$	V
I_{IH}	High level input current	$V_{IH} = V_{DD} = 3.15\text{ V}$			+100	μA
I_{IL}	Low level input current	$V_{IL} = 0, V_{DD} = 3.15\text{ V}$	-1			μA
Reference Divider input: f_r						
I_{IHR}	High level input current	$V_{IH} = V_{DD} = 3.15\text{ V}$			+100	μA
I_{ILR}	Low level input current	$V_{IL} = 0, V_{DD} = 3.15\text{ V}$	-100			μA
Counter and phase detector outputs: Dout, PD_D, PD_U						
V_{OLD}	Output voltage LOW	$I_{out} = 6\text{ mA}$			0.4	V
V_{OHD}	Output voltage HIGH	$I_{out} = -3\text{ mA}$	$V_{DD} - 0.4$			V
Lock detect outputs: (Cext, LD)						
V_{OLC}	Output voltage LOW, Cext	$I_{out} = 0.1\text{ uA}$			0.4	V
V_{OHC}	Output voltage HIGH, Cext	$I_{out} = -0.1\text{ uA}$	$V_{DD} - 0.4$			V
V_{OLLD}	Output voltage LOW, LD	$I_{out} = 1\text{ mA}$			0.4	V

Table 6. AC Characteristics

$V_{DD} = 3.0\text{ V}$, $-55^{\circ}\text{ C} < T_A < 125^{\circ}\text{ C}$, unless otherwise specified

Symbol	Parameter	Conditions	Min	Typ	Max	Units
Control Interface and Latches (see Figures 3, 4)						
f_{Clk}	Serial data clock frequency	(Note 1)			10	MHz
t_{ClkH}	Serial clock HIGH time		30			ns
t_{ClkL}	Serial clock LOW time		30			ns
t_{DSU}	Sdata set-up time to Sclk rising edge		10			ns
t_{DHLd}	Sdata hold time after Sclk rising edge		10			ns
t_{PW}	S_WR pulse width		30			ns
t_{CWR}	Sclk rising edge to S_WR rising edge		30			ns
t_{CE}	Sclk falling edge to E_WR transition		30			ns
t_{WRC}	S_WR falling edge to Sclk rising edge		30			ns
t_{EC}	E_WR transition to Sclk rising edge		30			ns
Main Divider (Including Prescaler)						
F_{in}	Operating frequency		500		3000	MHz
P_{Fin}	Input level range	External AC coupling	-5		5	dBm
		External AC coupling ($85^{\circ}\text{C} < T_A \leq 125^{\circ}\text{C}$)	0		5	dBm
Main Divider (Prescaler Bypassed)						
F_{in}	Operating frequency		50		300	MHz
P_{Fin}	Input level range	External AC coupling	0		5	dBm
		$85^{\circ}\text{C} < T_A \leq 125^{\circ}\text{C}$ External AC coupling	0		5	dBm
Reference Divider						
f_r	Operating frequency	(Note 3)			100	MHz
P_{fr}	Reference input power (Note 2)	Single ended input	0			dBm
Phase Detector						
f_c	Comparison frequency	(Note 3)			20	MHz
SSB Phase Noise : Output Referred ($F_{in} = 1.3\text{ GHz}$, $f_r = 10\text{ MHz}$, $f_c = 1.25\text{ MHz}$, $LBW = 70\text{ kHz}$)						
PN_{OR}	Output Referred Phase Noise	100 Hz Offset: $V_{DD} = 3.0\text{V}$, $T = 25^{\circ}\text{C}$		-87	(Note 4)	dBc/Hz
PN_{OR}	Output Referred Phase Noise	1000 Hz Offset: $V_{DD} = 3.0\text{V}$, $T = 25^{\circ}\text{C}$		-93	(Note 4)	dBc/Hz

- Note 1:** fclk is verified during the functional pattern test. Serial programming sections of the functional pattern are clocked at 10 MHz to verify fclk specification.
- Note 2:** CMOS logic levels can be used to drive reference input if DC coupled. Voltage input needs to be a minimum of 0.5 Vp-p. For optimum phase noise performance, the reference input falling edge rate should be faster than 80mV/ns.
- Note 3:** Parameter is guaranteed through characterization only and is not tested.
- Note 4:** All devices are screened to phase noise limits listed in Table 7. The magnitude of the tester uncertainty precludes testing phase noise as part of qualification testing. These parameters are also exempt from PDA requirements.

Table 7. Phase Noise Test

Test name	Conditions	Max	Units
Phase Noise	100 Hz Offset	-73	dBc/Hz
	1000 Hz Offset	-83	dBc/Hz

Functional Description

The PE83340 consists of a prescaler, counters, a phase detector and control logic. The dual modulus prescaler divides the VCO frequency by either 10 or 11, depending on the value of the modulus select. Counters "R" and "M" divide the reference and prescaler output, respectively, by integer values stored in a 20-bit register. An additional counter ("A") is used in the modulus select logic.

The phase-frequency detector generates up and down frequency control signals. Data is written into the internal registers via the three wire serial bus. There are also various operational and test modes and a lock detect output.

Figure 3. Functional Block Diagram

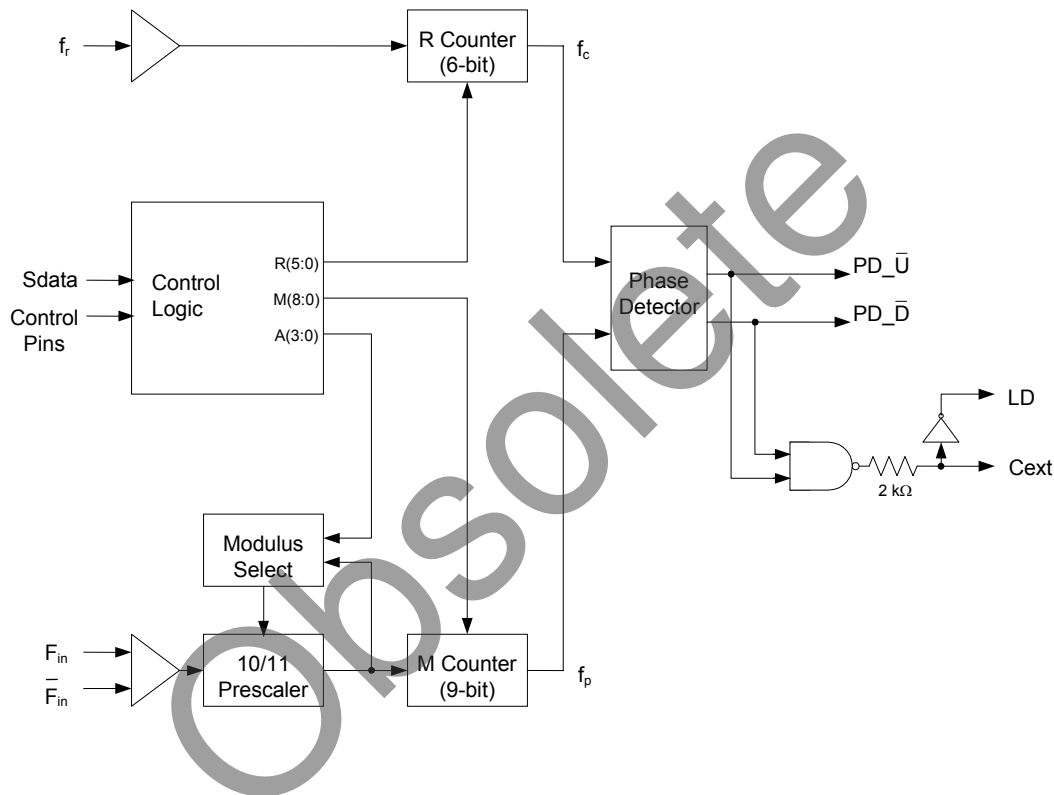

Main Counter Chain

Normal Operating Mode

Setting the Pre_en control bit “low” enables the ÷10/11 prescaler. The main counter chain then divides the RF input frequency (F_{in}) by an integer derived from the values in the “M” and “A” counters.

In this mode, the output from the main counter chain (f_p) is related to the VCO frequency (F_{in}) by the following equation:

$$f_p = F_{in} / [10 \times (M + 1) + A] \quad (1)$$

where $A \leq M + 1$, $1 \leq M \leq 511$

When the loop is locked, F_{in} is related to the reference frequency (f_r) by the following equation:

$$F_{in} = [10 \times (M + 1) + A] \times (f_r / (R+1)) \quad (2)$$

where $A \leq M + 1$, $1 \leq M \leq 511$

A consequence of the upper limit on A is that F_{in} must be greater than or equal to $90 \times (f_r / (R+1))$ to obtain contiguous channels. The A counter can accept values as high as 15, but in typical operation it will cycle from 0 to 9 between increments in M.

Programming the M counter with the minimum allowed value of “1” will result in a minimum M counter divide ratio of “2”.

Prescaler Bypass Mode

Setting the frequency control register bit Pre_en “high” allows F_{in} to bypass the ÷10/11 prescaler. In this mode, the prescaler and A counter are powered down, and the input VCO frequency is divided by the M counter directly. The following equation relates F_{in} to the reference frequency f_r :

$$F_{in} = (M + 1) \times (f_r / (R+1)) \quad (3)$$

where $1 \leq M \leq 511$

Reference Counter

The reference counter chain divides the reference frequency f_r down to the phase detector comparison frequency f_c .

The output frequency of the 6-bit R Counter is related to the reference frequency by the following equation:

$$f_c = f_r / (R + 1) \quad (4)$$

where $0 \leq R \leq 63$

Note that programming R with “0” will pass the reference frequency (f_r) directly to the phase detector.

Register Programming

Serial Interface Mode

While the E_WR input is “low” and the S_WR input is “low”, serial input data (Sdata input), B_0 to B_{19} , are clocked serially into the primary register on the rising edge of Sclk, MSB (B_0) first. The contents from the primary register are transferred into the secondary register on the rising edge of either S_WR according to the timing diagrams shown in Figure 4. Data are transferred to the counters as shown in Table 7 on page 9.

The double buffering provided by the primary and secondary registers allows for “ping-pong” counter control using the FSELS input. When FSELS is “high”, the primary register contents set the counter inputs. When FSELS is “low”, the secondary register contents are utilized.

While the E_WR input is “high” and the S_WR input is “low”, serial input data (Sdata input), B_0 to B_7 , are clocked serially into the enhancement register on the rising edge of Sclk, MSB (B_0) first. The enhancement register is double buffered to prevent inadvertent control changes during serial loading, with buffer capture of the serially entered data performed on the falling edge of E_WR according to the timing diagram shown in Figure 4. After the falling edge of E_WR, the data provide control bits as shown in Table 8 on page 9 will have their bit functionality enabled by asserting the Enh input “low”.

Table 7. Primary Register Programming

Interface Mode	Enh	R ₅	R ₄	M ₆	M ₇	Pre_en	M ₆	M ₅	M ₄	M ₃	M ₂	M ₁	M ₀	R ₃	R ₂	R ₁	R ₀	A ₃	A ₂	A ₁	A ₀
Serial*	1	B ₀	B ₁	B ₂	B ₃	B ₄	B ₅	B ₆	B ₇	B ₈	B ₉	B ₁₀	B ₁₁	B ₁₂	B ₁₃	B ₁₄	B ₁₅	B ₁₆	B ₁₇	B ₁₈	B ₁₉

*Serial data clocked serially on Sclk rising edge while E_WR “low” and captured in secondary register on S_WR rising edge.



Table 8. Enhancement Register Programming

Interface Mode	Enh	Reserved	Reserved	f _p output	Power down	Counter load	MSEL output	f _c output	Reserved
Serial*	0	B ₀	B ₁	B ₂	B ₃	B ₄	B ₅	B ₆	B ₇

*Serial data clocked serially on Sclk rising edge while E_WR “high” and captured in the double buffer on E_WR falling edge.



Figure 4. Serial Interface Mode Timing Diagram

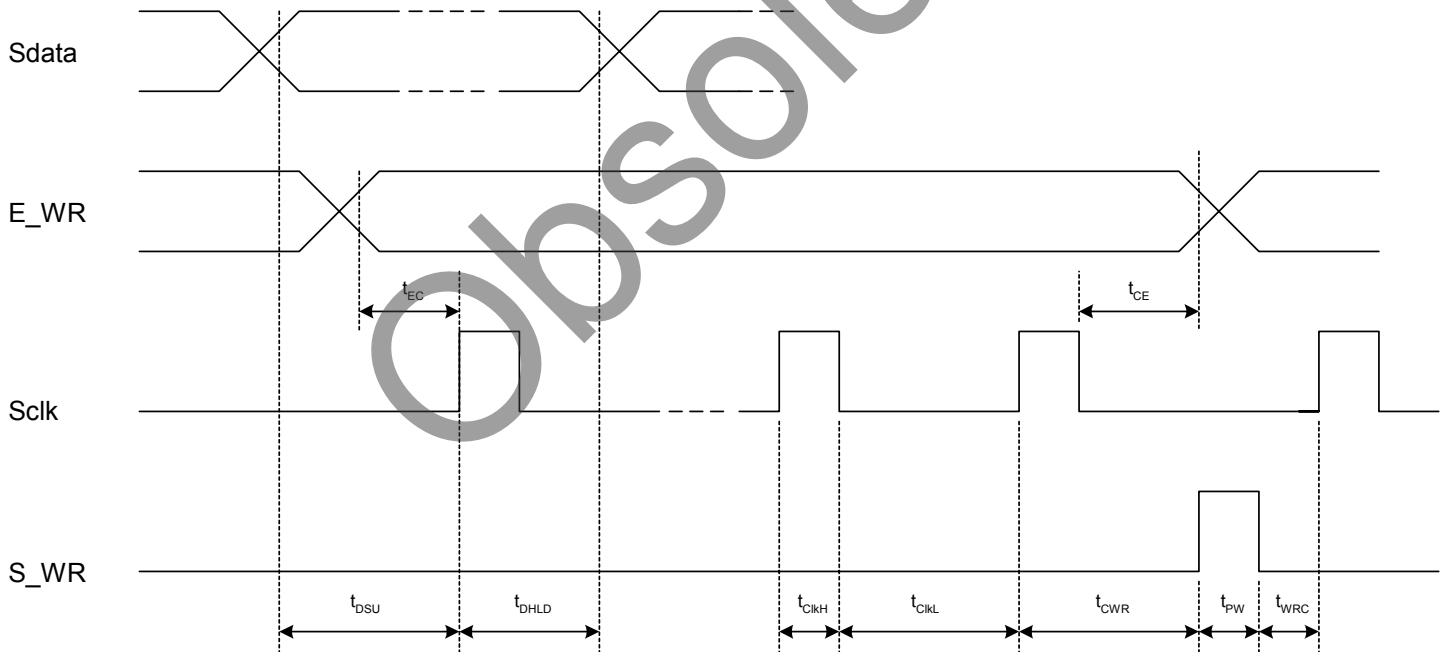

Enhancement Register

The functions of the enhancement register bits are shown below with all bits active “high”.

Table 9. Enhancement Register Bit Functionality

Bit Function		Description
Bit 0	Reserved**	
Bit 1	Reserved**	
Bit 2	f_p output	Drives the M counter output onto the Dout output.
Bit 3	Power down	Power down of all functions except programming interface.
Bit 4	Counter load	Immediate and continuous load of counter programming.
Bit 5	MSEL output	Drives the internal dual modulus prescaler modulus select (MSEL) onto the Dout output.
Bit 6	f_c output	Drives the reference counter output onto the Dout output
Bit 7	Reserved**	

** Program to 0

Phase Detector

The phase detector is triggered by rising edges from the main Counter (f_p) and the reference counter (f_c). It has two outputs, namely PD_U, and PD_D. If the divided VCO leads the divided reference in phase or frequency (f_p leads f_c), PD_D pulses “low”. If the divided reference leads the divided VCO in phase or frequency (f_c leads f_p), PD_U pulses “low”. The width of either pulse is directly proportional to phase offset between the two input signals, f_p and f_c .

The phase detector gain is equal to $2.70 \text{ V} / 2\pi$, which numerically yields $0.43 \text{ V} / \text{Radian}$.

PD_U and PD_D drive an active loop filter which controls the VCO tune voltage. PD_U pulses result in an increase in VCO frequency and PD_D results in a decrease in VCO frequency, for a positive K_v VCO.

A lock detect output, LD is also provided, via the pin Cext. Cext is the logical “NAND” of PD_U and PD_D waveforms, which is driven through a series 2 kohm resistor. Connecting Cext to an external shunt capacitor provides low pass filtering of this signal. Cext also drives the input of an internal inverting comparator with an open drain output. Thus LD is an “AND” function of PD_U and PD_D.

Figure 5. Package Drawing

20-lead TSSOP (JEDEC MO-153-AC)

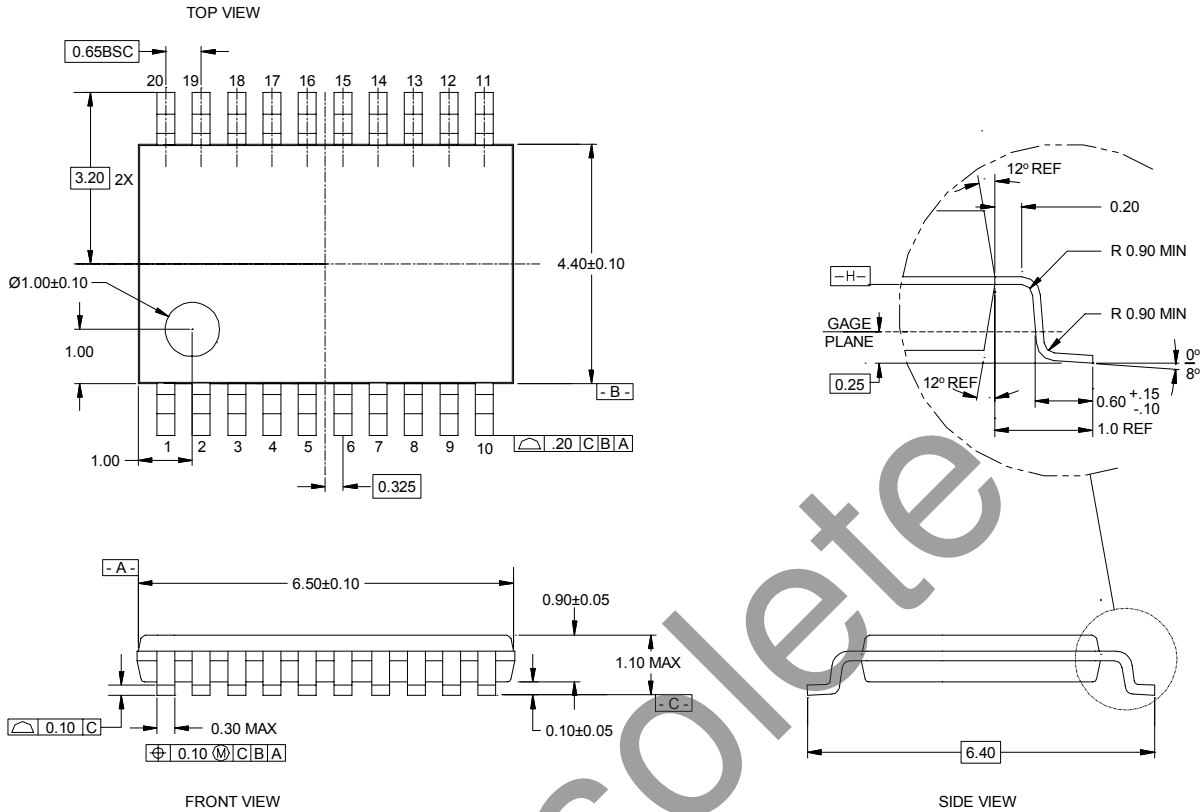

Table 10. Ordering Information

Order Code	Part Marking	Description	Package	Shipping Method
83340-11	PE83340	PE83340-20TSSOP-74A	20-lead TSSOP	74 units / Tube
83340-12	PE83340	PE83340-20TSSOP-200C	20-lead TSSOP	2000 units / T&R
83340-00	PE83340EK	PE83340-20TSSOP-EVAL KIT	20-lead TSSOP	1 / Box

Sales Offices

United States

Peregrine Semiconductor Corp.

6175 Nancy Ridge Drive
San Diego, CA 92121
Tel 1-858-455-0660
Fax 1-858-455-0770

Japan

Peregrine Semiconductor K.K.

5A-5, 5F Imperial Tower
1-1-1 Uchisaiwaicho, Chiyoda-ku
Tokyo 100-0011 Japan
Tel: 011-81-03-3507-5755
Fax: 011-81-03-3507-5601

Europe

Peregrine Semiconductor Europe

Aix-En-Provence Office
Parc Club du Golf, bat 9
13856 Aix-En-Provence Cedex 3
France
Tel 011-33-0-4-4239-3360
Fax 011-33-0-4-4239-7227

For a list of representatives in your area, please refer to our Web site at: <http://www.peregrine-semi.com>

Data Sheet Identification

Advance Information

The product is in a formative or design stage. The data sheet contains design target specifications for product development. Specifications and features may change in any manner without notice.

The information in this data sheet is believed to be reliable. However, Peregrine assumes no liability for the use of this information. Use shall be entirely at the user's own risk.

No patent rights or licenses to any circuits described in this data sheet are implied or granted to any third party.

Preliminary Specification

The data sheet contains preliminary data. Additional data may be added at a later date. Peregrine reserves the right to change specifications at any time without notice in order to supply the best possible product.

Peregrine's products are not designed or intended for use in devices or systems intended for surgical implant, or in other applications intended to support or sustain life, or in any application in which the failure of the Peregrine product could create a situation in which personal injury or death might occur. Peregrine assumes no liability for damages, including consequential or incidental damages, arising out of the use of its products in such applications.

Product Specification

The data sheet contains final data. In the event Peregrine decides to change the specifications, Peregrine will notify customers of the intended changes by issuing a PCN (Product Change Notice).

Peregrine products are protected under one or more of the following U.S. patents: 6,090,648; 6,057,555; 5,973,382; 5,973,363; 5,930,638; 5,920,233; 5,895,957; 5,883,396; 5,864,162; 5,863,823; 5,861,336; 5,663,570; 5,610,790; 5,600,169; 5,596,205; 5,572,040; 5,492,857; 5,416,043. Other patents are pending.

Peregrine, the Peregrine logotype, Peregrine Semiconductor Corp., and UTSi are registered trademarks of Peregrine Semiconductor Corporation. Copyright © 2003 Peregrine Semiconductor Corp. All rights reserved.