

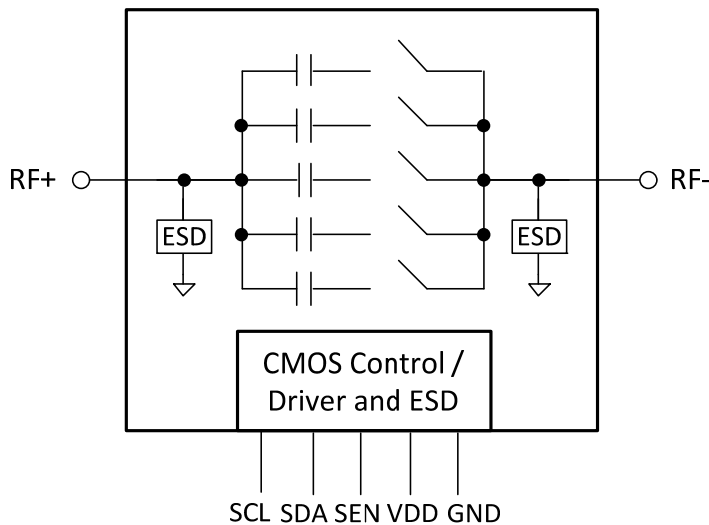
**Product Description**

PE621020 is a DuNE™-enhanced Digitally Tunable Capacitor (DTC) based on Peregrine’s UltraCMOS® technology. This highly versatile product supports a wide variety of tuning circuit topologies in series or shunt configurations. DTC products provide a monolithically integrated impedance tuning solution for demanding RF applications.

PE621010 offers high RF power handling and ruggedness while meeting challenging harmonic and linearity requirements enabled by Peregrine’s HaRP™ technology. The device is controlled through the widely supported 3-wire (SPI compatible) 8-bit serial interface. All decoding and biasing is integrated on-chip and no external bypassing or filtering components are required.

DuNE™ devices feature ease of use while delivering superior RF performance in the form of tuning accuracy, monotonicity, tuning ratio, power handling, size, and quality factor. With built-in bias voltage generation and ESD protection, DTC products provide a monolithically integrated tuning solution for demanding RF applications.

**Figure 1. Functional Block Diagram**

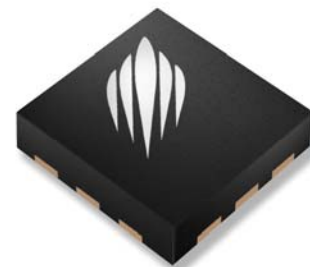


**UltraCMOS® Digitally Tunable Capacitor (DTC) Optimized for 2G/3G/4G Impedance Tuning Applications, 100-3000 MHz**

**Features**

- 5-bit 32-state Digitally Tunable Capacitor
- C = 1.88 - 14.0 pF (7.4:1 tuning ratio) in discrete 391 fF steps
- RF power handling (up to +26 dBm, 6 V<sub>PK</sub> RF) and high linearity for diversity applications
- Wide power supply range (2.3 to 3.1V) and low current consumption (typ. I<sub>DD</sub> = 30 µA @ 2.8V)
- 2 x 2 x 0.55 mm QFN package
- High ESD tolerance of 2kV HBM on all pins
- Applications include:
  - Antenna tuning
  - Tunable filters
  - Impedance matching

**Figure 2. Package Type**  
12-lead 2 x 2 x 0.55 mm QFN package



**Table 1. Electrical Specifications @ 25 °C, V<sub>DD</sub> = 2.8V  
(In shunt configuration between 50 Ω ports, RF- connected to GND)**

Parameter	Condition	Min	Typ	Max	Unit
Operating Frequency Range		100		3000	MHz
Minimum Capacitance	State 00000, 100 MHz (RF+ to Grounded RF-)	-10%	1.88	+10%	pF
Maximum Capacitance	State 11111, 100 MHz (RF+ to Grounded RF-)	-10%	14.0	+10%	pF
Tuning Ratio	C <sub>max</sub> /C <sub>min</sub> , 100 MHz		7.4:1		
Step Size	5 bits (32 states), constant step size (100 MHz)		0.391		pF
Quality Factor (C <sub>min</sub> ) <sup>1</sup>	698 - 960 MHz, with L <sub>s</sub> removed 1710 - 2170 MHz, with L <sub>s</sub> removed		50 28		
Quality Factor (C <sub>max</sub> ) <sup>1</sup>	698 - 960 MHz, with L <sub>s</sub> removed 1710 - 2170 MHz, with L <sub>s</sub> removed		25 5		
Self Resonant Frequency	State 00000 State 11111		4.7 1.6		GHz
Harmonics <sup>4</sup>	2fo, 3fo: 698 to 915 MHz, Pin +26 dBm, 50 Ω 2fo, 3fo: 1710 to 1910 MHz, Pin +26 dBm, 50 Ω			-36 -36	dBm dBm
IMD3	Bands I,II,V/VIII, +20 dBm CW @ TX freq, -15 dBm CW @ 2Tx-Rx freq, 50 Ω		-111	-105	dBm
Switching Time <sup>2,3</sup>	State change to 10/90% delta capacitance between any two states			10	μs
Start-up Time <sup>2</sup>	Time from V <sub>DD</sub> within specification to all performances within specification			100	μs
Wake-up Time <sup>2,3</sup>	State change from standby mode to RF state to all performances within specification			100	μs

Note: 1. Q for a Shunt DTC based on a Series RLC equivalent circuit  
 $Q = X_C / R = (X - X_L) / R$ , where  $X = X_L + X_C$ ,  $X_L = 2\pi f L$ ,  $X_C = -1 / (2\pi f C)$ , which is equal to removing the effect of parasitic inductance L<sub>s</sub>  
2. DC path to ground at RF+ and RF- must be provided to achieve specified performance  
3. State change activated on falling edge of SEN following data word  
4. Between 50 Ω ports in series or shunt configuration using a pulsed RF input with 4620 vs period, 50% duty cycle, measured per 3GPPTS45.005

Figure 3. Pin Configuration (Top View)

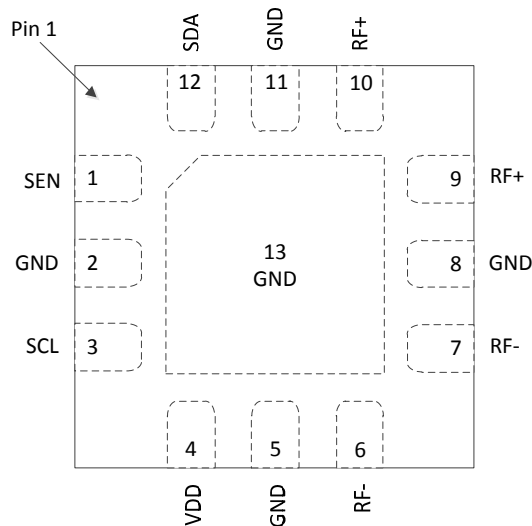


Table 2. Pin Descriptions

Pin #	Pin Name	Description
1	SEN	Serial Enable (Active High)
2	GND	Digital and RF Ground
3	SCL	Serial Interface Clock Input
4	VDD	Supply
5	GND	Digital and RF Ground
6	RF-	Negative RF Port <sup>1</sup>
7	RF-	Negative RF Port <sup>1</sup>
8	GND	Digital and RF Ground <sup>3</sup>
9	RF+	Positive RF Port <sup>2</sup>
10	RF+	Positive RF Port <sup>2</sup>
11	GND	Digital and RF Ground
12	SDA	Serial Interface Data Input
13	GND	Digital and RF Ground <sup>3</sup>

Notes: 1. Pins 6 and 7 must be tied together on PCB board to reduce inductance  
 2. Pins 9 and 10 must be tied together on PCB board to reduce inductance  
 3. Pin 2, 5, 8, 11 and 13 must be connected together on PCB

### Moisture Sensitivity Level

The Moisture Sensitivity Level rating for the PE621020 in the 12-lead 2 x 2 QFN package is MSL1.

### Latch-Up Avoidance

Unlike conventional CMOS devices, UltraCMOS<sup>®</sup> devices are immune to latch-up.

Table 3. Operating Ranges<sup>1</sup>

Parameter	Min	Typ	Max	Unit
V <sub>DD</sub> Supply Voltage	2.3	2.8	3.1	V
I <sub>DD</sub> Power Supply Current <sup>5</sup>		30	75	μA
I <sub>DD</sub> Standby Current <sup>5</sup>		20	45	μA
Control Voltage High	1.2		3.1	V
Control Voltage Low	0		0.2	V
Peak Operating RF Voltage <sup>4</sup>			6	V <sub>PK</sub>
V <sub>P</sub> to V <sub>M</sub>			6	V <sub>PK</sub>
V <sub>P</sub> to RFGND			6	V <sub>PK</sub>
V <sub>M</sub> to RFGND			6	V <sub>PK</sub>
RF Input Power (50Ω) <sup>3,4</sup>			+26	dBm
Shunt				
Input Control Current		1	10	μA
Operating Temperature Range	-40	+25	+85	°C
Storage Temperature Range	-65	+25	+150	°C

Notes: 1. Operation should be restricted to the limits in the Operating Ranges table  
 2. The DTC is active when STBY is low (set to 0) and in low-current stand-by mode when high (set to 1)  
 3. Maximum CW power available from a 50Ω source in shunt configuration  
 4. RF+ to RF- and RF+ and/or RF- to ground. Cannot exceed 6 V<sub>PK</sub> or max RF input power (whichever occurs first)  
 5. I<sub>DD</sub> current typical value is based on V<sub>DD</sub> = 2.8V. Max I<sub>DD</sub> is based on V<sub>DD</sub> = 3.1V

Table 4. Absolute Maximum Ratings

Symbol	Parameter/Conditions	Min	Max	Unit
V <sub>ESD</sub>	ESD Voltage (HBM, MIL_STD 883 Method 3015.7)		2000	V

Exceeding absolute maximum ratings may cause permanent damage. Operation between operating range maximum and absolute maximum for extended periods may reduce reliability.

### Electrostatic Discharge (ESD) Precautions

When handling this UltraCMOS<sup>®</sup> device, observe the same precautions that you would use with other ESD-sensitive devices. Although this device contains circuitry to protect it from damage due to ESD, precautions should be taken to avoid exceeding the specified rating.

Performance Plots @ 25°C and 2.8V unless otherwise specified

Figure 4. Measured Shunt C (@ 100 MHz) vs State (temperature)

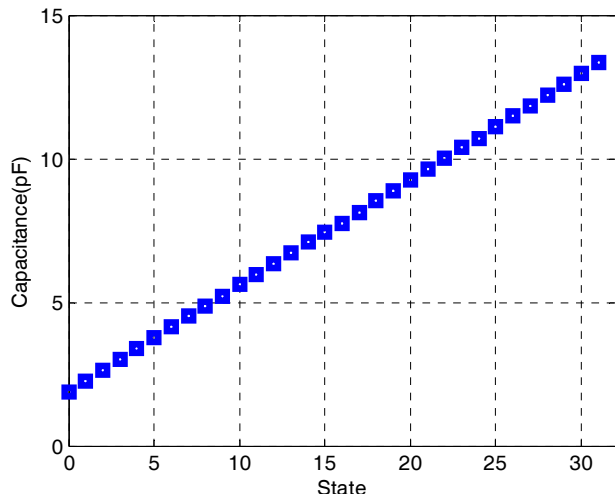


Figure 5. Measured Shunt S<sub>11</sub> (major states)

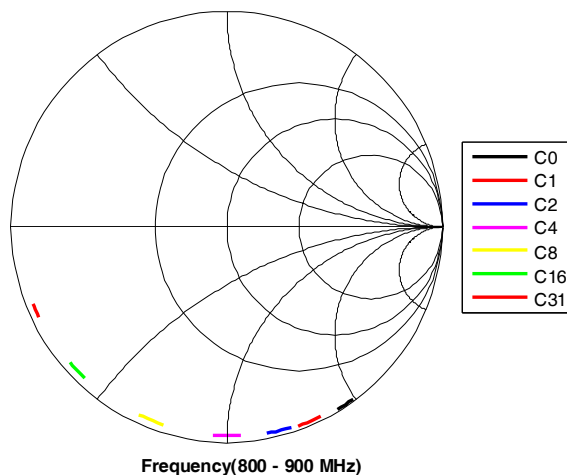


Figure 6. Measured Step Size vs State (frequency)

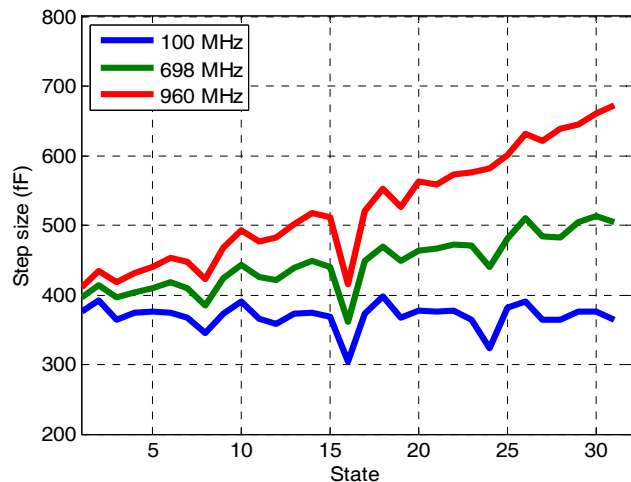


Figure 7. Measured Series S<sub>11</sub>/S<sub>22</sub> (major states)

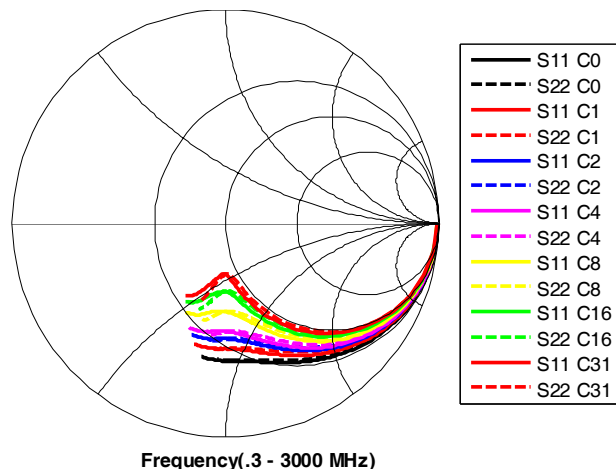


Figure 8. Measured Shunt C vs Frequency (major states)

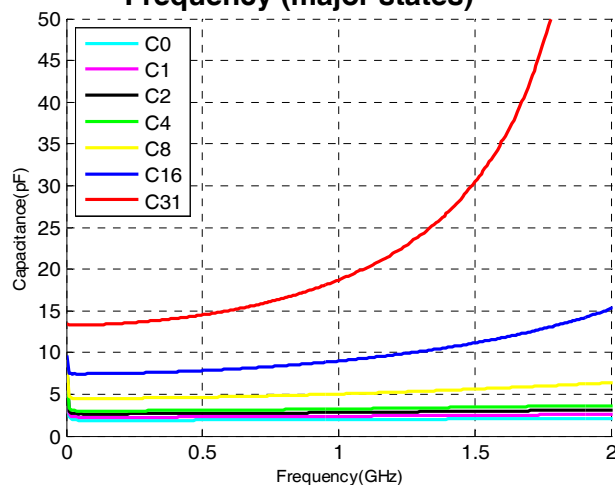
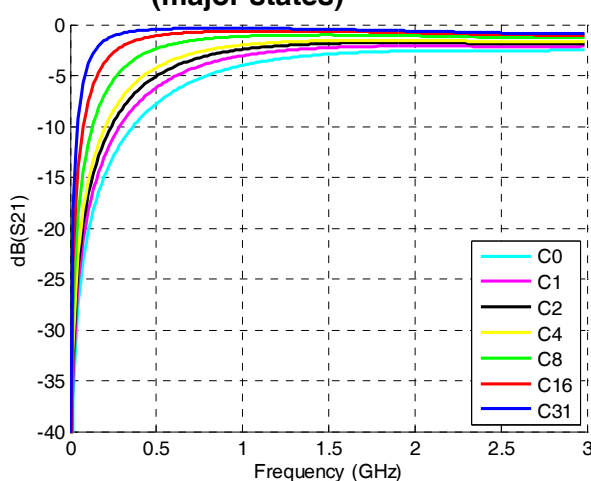
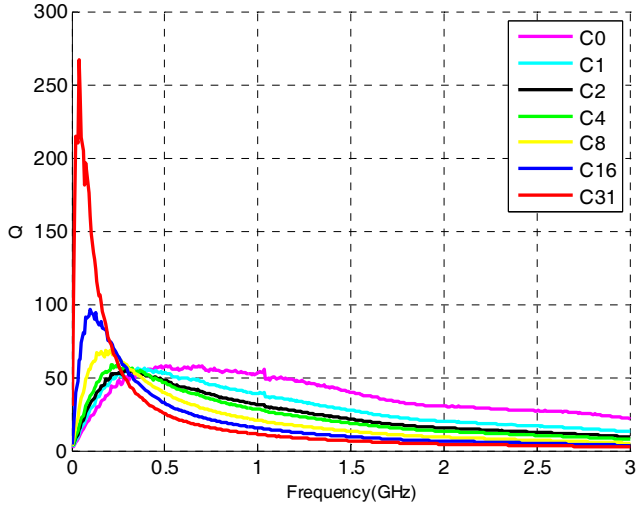


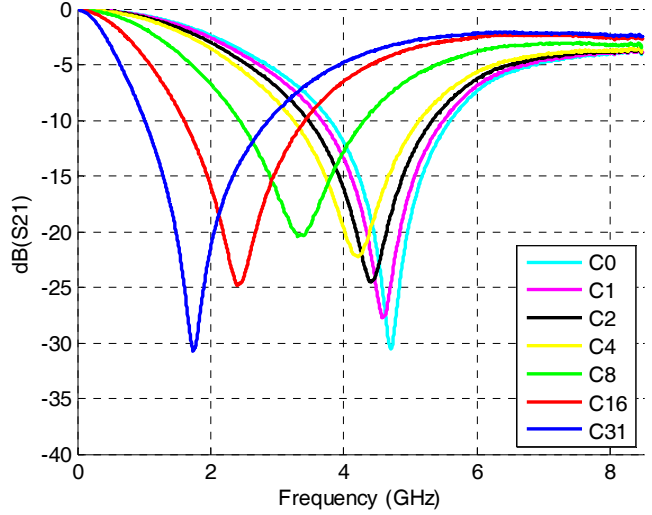
Figure 9. Measured Series S<sub>21</sub> vs Frequency (major states)



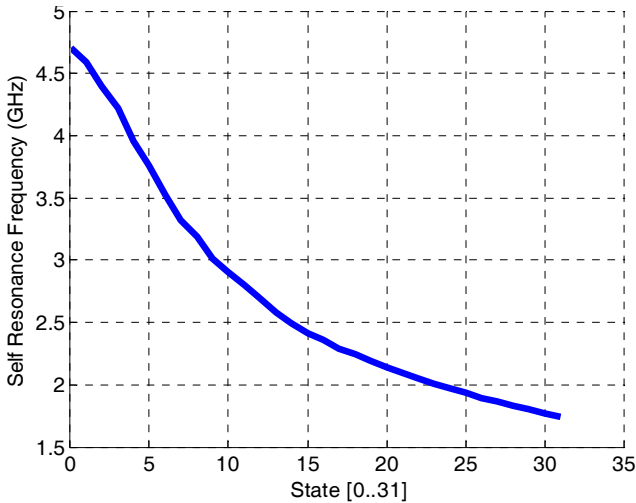
**Figure 10. Measured Shunt Q vs Frequency (major states)**



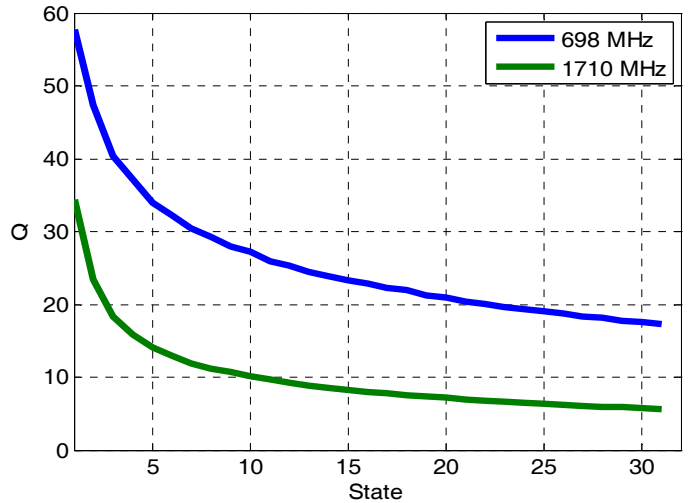
**Figure 11. Measured 2-Port Shunt S21 vs Frequency (major states)**



**Figure 12. Measured Self Resonance Frequency vs State**



**Figure 13. Measured Shunt Q vs State**



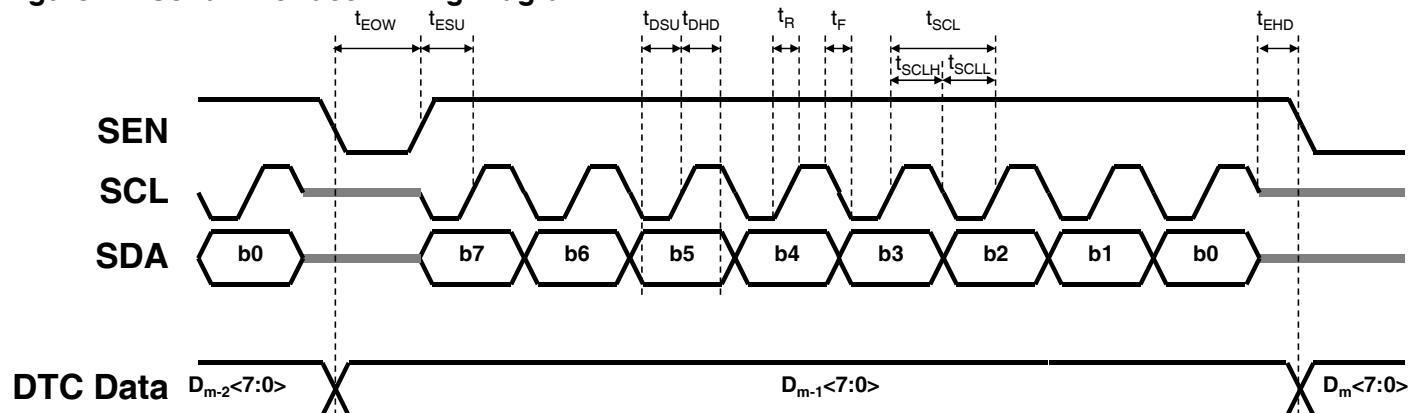
### Serial Interface Operation and Sharing

The PE621020 is controlled by a three wire SPI-compatible interface with enable active high. As shown in *Figure 14*, the serial master initiates the start of a telegram by driving the SEN (Serial Enable) line high. Each bit of the 8-bit telegram (MSB first in) is clocked in on the rising edge of SCL (Serial Clock), as shown in *Table 5* and *Figure 14*. Transitions on SDA (Serial Data) are allowed on the falling edge of SCL. The DTC activates the data on the falling edge of SEN. The DTC does not count how many bits are clocked and only maintains the last 8 bits it received.

More than 1 DTC can be controlled by one interface by utilizing a dedicated enable (SEN) line for each DTC. SDA, SCL, and V<sub>DD</sub> lines may be shared as shown in *Figure 15*. Dedicated SEN lines act as a chip select such that each DTC will only respond to serial transactions intended for them. This makes each DTC change states sequentially as they are programmed.

Alternatively, a dedicated SDA line with common SEN can be used. This allows all DTCs to change states simultaneously, but requires all DTCs to be programmed even if the state is not changed.

**Figure 14. Serial Interface Timing Diagram**



**Table 5. 8-Bit Serial Programming Register Map**

b7	b6	b5	b4	b3	b2	b1	b0
0 <sup>1</sup>	0 <sup>1</sup>	STB <sup>2</sup>	d4	d3	d2	d1	d0

MSB (first in)

LSB (last in)

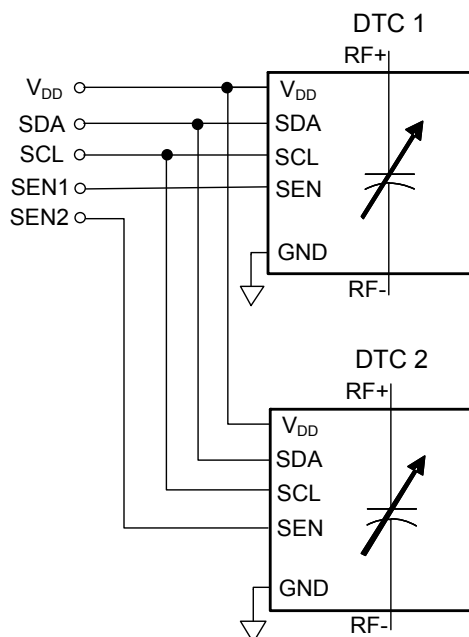
Note: 1. These bits are reserved and must be written to 0 for proper operation  
 2. The DTC is active when low (set to 0) and in low-current stand-by mode when high (set to 1)

**Table 6. Serial Interface AC Characteristics**

2.3V < V<sub>DD</sub> < 3.1V, -40 °C < T<sub>A</sub> < +85 °C, unless otherwise specified

Symbol	Parameter	Min	Max	Unit
t <sub>SCL</sub>	Serial Clock Period	38.4		ns
t <sub>SCLL</sub>	SCL Low Time	13.2		ns
t <sub>SCLH</sub>	SCL High Time	13.2		ns
t <sub>R</sub>	SCL, SDA, SEN Rise Time		6.5	ns
t <sub>F</sub>	SCL, SDA, SEN Fall Time		6.5	ns
t <sub>ESU</sub>	SEN rising edge to SCL rising edge	19.2		ns
t <sub>EHD</sub>	SCL falling edge to SEN falling edge	19.2		ns
t <sub>DSU</sub>	SDA valid to SCL rising edge	13.2		ns
t <sub>DHD</sub>	SDA valid after SCL rising edge	13.2		ns
t <sub>EOW</sub>	SEN falling edge to SEN rising edge	38.4		ns

**Figure 15. Recommended Bus Sharing**



### Equivalent Circuit Model Description

The DTC Equivalent Circuit Model includes all parasitic elements and is accurate in both Series and Shunt configurations, reflecting physical circuit behavior accurately and providing very close correlation to measured data. It can easily be used in circuit simulation programs. Simple equations are provided for the state dependent parameters.

The Tuning Core capacitance  $C_S$  represents capacitance between RF+ and RF- ports. It is linearly proportional to state (0 to 31 in decimal) in a discrete fashion. The Series Tuning Ratio is defined as  $C_{Smax}/C_{Smin}$ .

$C_{P1}$  and  $C_{P2}$  represent the circuit and package parasitics from RF ports to GND. In shunt configuration the total capacitance of the DTC is higher due to parallel combination of  $C_P$  and  $C_S$ . The capacitance seen looking into RF+ is  $C_S+C_{P1}$  (when RF- is grounded) and  $C_S+C_{P2}$  for RF-, respectively. In Series configuration,  $C_S$  and  $C_P$  do not add in parallel and the DTC appears as an impedance transformation network.

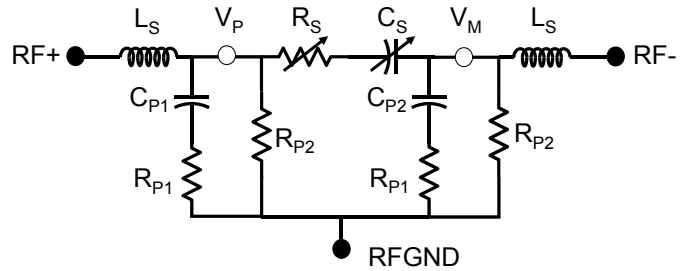
Parasitic inductance due to circuit and package is modeled as  $L_S$  and causes the apparent capacitance of the DTC to increase with frequency until it reaches Self Resonant Frequency (SRF). The value of SRF depends on state and is approximately inversely proportional to the square root of capacitance.

The overall dissipative losses of the DTC are modeled by  $R_S$ ,  $R_{P1}$  and  $R_{P2}$  resistors. The parameter  $R_S$  represents the Equivalent Series Resistance (ESR) of the tuning core and is dependent on state.  $R_{P1}$  and  $R_{P2}$  represent losses due to the parasitic and biasing networks.

**Table 7. Maximum Operating RF Voltage**

Condition	Limit
$V_P$ to $V_M$	6 $V_{PK}$
$V_P$ to RFGND	6 $V_{PK}$
$V_M$ to RFGND	6 $V_{PK}$

**Figure 16. Equivalent Circuit Model Schematic**



**Table 8. Equivalent Circuit Model Parameters**

Variable	Equation (state = 0, 1, 2...31)	Unit
$C_S$	$0.394 * state + 1.456$	pF
$R_S$	$15 / (state + 15 / (state + 0.4)) + 0.4$	$\Omega$
$C_{P1}$	$-0.0026 * state + 0.4155$	pF
$C_{P2}$	$0.0029 * state + 0.4914$	pF
$R_{P1}$	4	$\Omega$
$R_{P2}$	$22000 + 6 * (state)^3$	$\Omega$
$L_S$	0.4	nH

**Table 9. Equivalent Circuit Data**

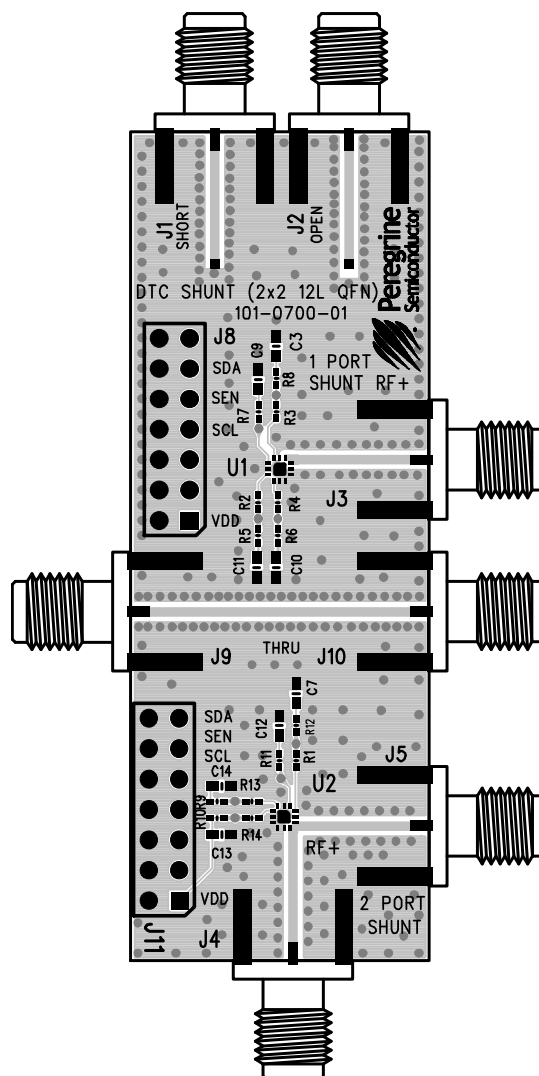
State			DTC Core		Parasitic Elements		
Hex	Bin	Dec	$C_S$ [pF]	$R_S$ [ $\Omega$ ]	$C_{P1}$ [pF]	$C_{P2}$ [pF]	$R_{P2}$ [k $\Omega$ ]
0x00	00000	0	1.40	0.80	0.42	0.49	22.0
0x01	00001	1	1.79	1.68	0.41	0.49	22.0
0x02	00010	2	2.19	2.22	0.41	0.50	22.0
0x03	00011	3	2.58	2.42	0.41	0.50	22.2
0x04	00100	4	2.98	2.42	0.41	0.50	22.4
0x05	00101	5	3.37	2.33	0.40	0.51	22.8
0x06	00110	6	3.76	2.20	0.40	0.51	23.3
0x07	00111	7	4.16	2.06	0.40	0.51	24.1
0x08	01000	8	4.55	1.93	0.39	0.51	25.1
0x09	01001	9	4.95	1.82	0.39	0.52	26.4
0x0A	01010	10	5.34	1.71	0.39	0.52	28.0
0x0B	01011	11	5.73	1.62	0.39	0.52	30.0
0x0C	01100	12	6.13	1.54	0.38	0.53	32.4
0x0D	01101	13	6.52	1.46	0.38	0.53	35.2
0x0E	01110	14	6.92	1.40	0.38	0.53	38.5
0x0F	01111	15	7.31	1.34	0.38	0.53	42.3
0x10	10000	16	7.70	1.29	0.37	0.54	46.6
0x11	10001	17	8.10	1.24	0.37	0.54	51.5
0x12	10010	18	8.49	1.20	0.37	0.54	55.0
0x13	10011	19	8.89	1.16	0.37	0.55	63.2
0x14	10100	20	9.28	1.12	0.36	0.55	70.0
0x15	10101	21	9.67	1.09	0.36	0.55	77.6
0x16	10110	22	10.07	1.06	0.36	0.56	85.9
0x17	10111	23	10.46	1.03	0.36	0.56	95.0
0x18	11000	24	10.86	1.01	0.35	0.56	104.9
0x19	11001	25	11.25	0.99	0.35	0.56	115.8
0x1A	11010	26	11.64	0.96	0.35	0.57	127.5
0x1B	11011	27	12.04	0.94	0.35	0.57	140.1
0x1C	11100	28	12.43	0.93	0.34	0.57	153.7
0x1D	11101	29	12.83	0.91	0.34	0.58	168.3
0x1E	11110	30	13.22	0.89	0.34	0.58	184.0
0x1F	11111	31	13.61	0.88	0.33	0.58	200.7

### Evaluation Board

The 101-0700 Evaluation Board (EVB) was designed for accurate measurement of the DTC impedance and loss. Two configurations are available: 1 Port Shunt (J3) and 2 Port Shunt (J4, J5). Three calibration standards are provided. The open (J2) and short (J1) standards (104 ps delay) are used for performing port extensions and accounting for electrical length and transmission line loss. The Thru (J9, J10) standard can be used to estimate PCB transmission line losses for scalar de-embedding of the 2 Port Shunt configuration (J4, J5).

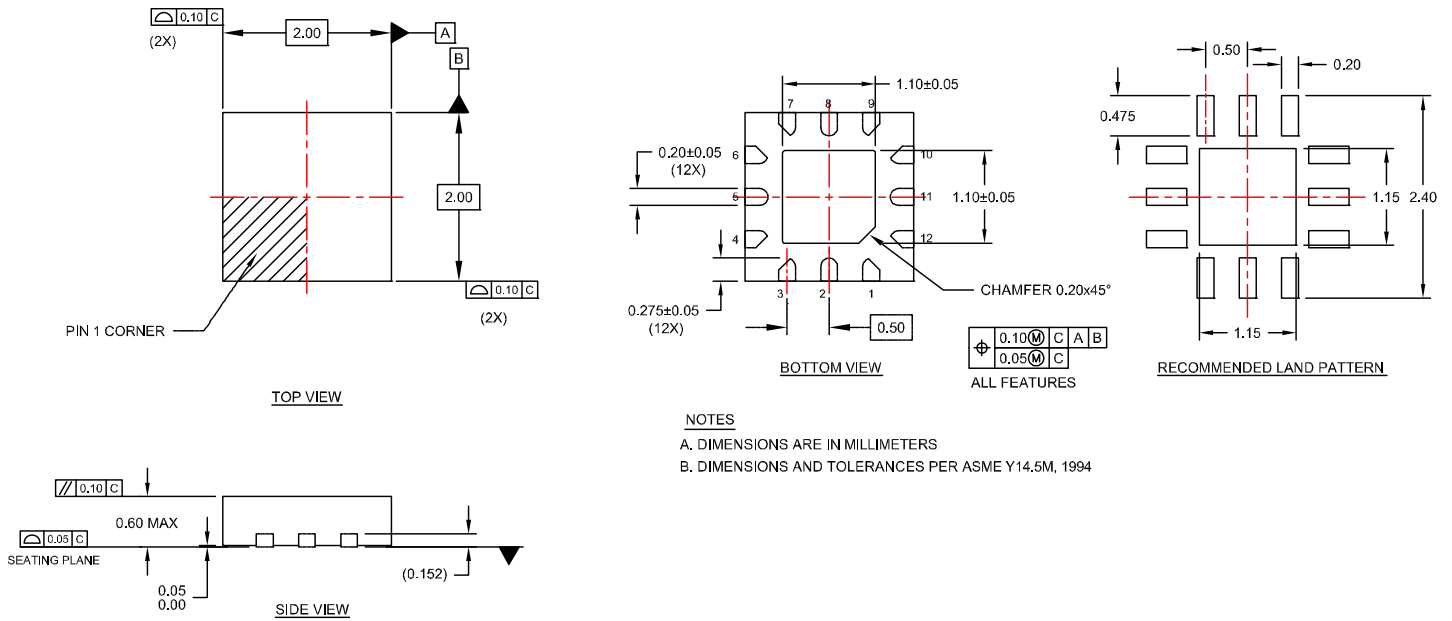
The board consists of a 4 layer stack with 2 outer layers made of Rogers 4350B ( $\epsilon_r = 3.48$ ) and 2 inner layers of FR4 ( $\epsilon_r = 4.80$ ). The total thickness of this board is 62 mils (1.57 mm). The inner layers provide a ground plane for the transmission lines. Each transmission line is designed using a coplanar waveguide with ground plane (CPWG) model using a trace width of 32 mils (0.813 mm), gap of 15 mils (0.381 mm), and a metal thickness of 1.4 mils (0.036 mm).

Figure 17. Evaluation Board Layout

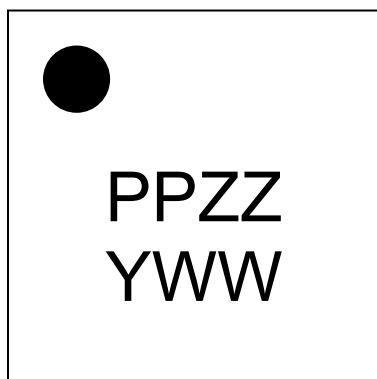




**Figure 18. Package Drawing**  
12-lead 2 x 2 x 0.55 mm QFN



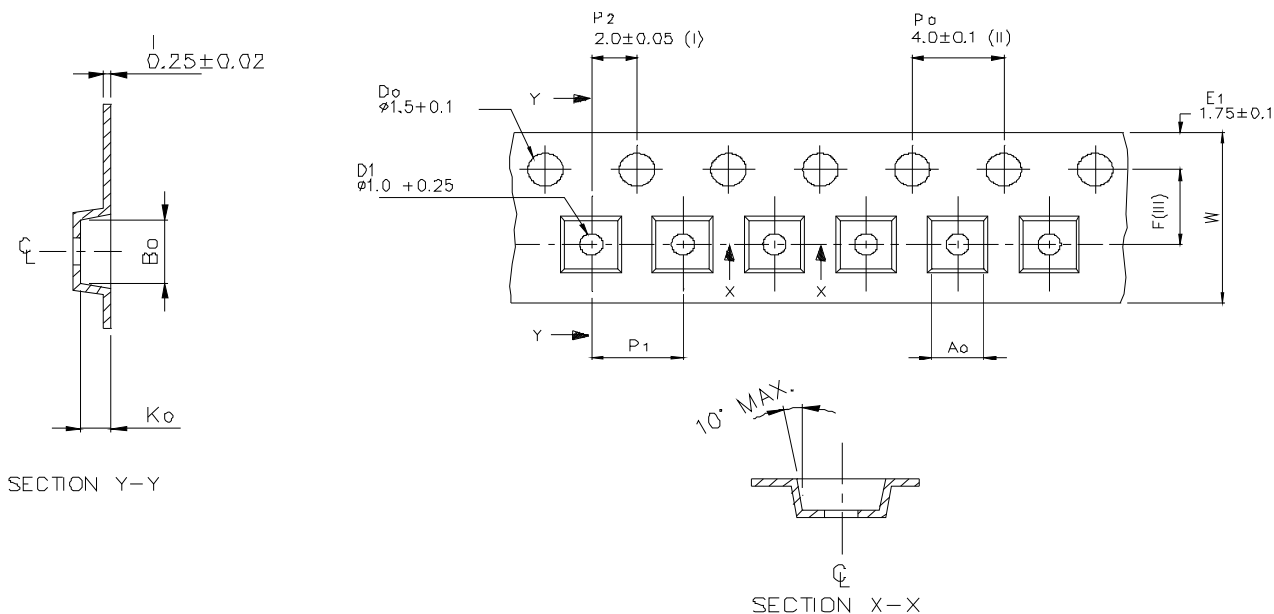
**Figure 19. Top Marking Specifications**



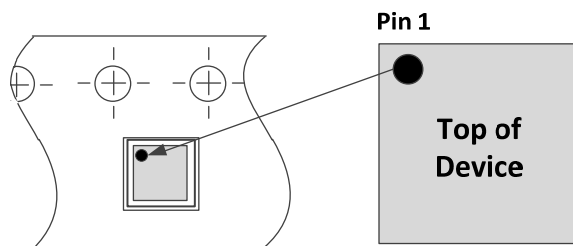
17-0112

Marking Spec Symbol	Package Marking	Definition
PP	CP	Part number marking for PE621020
ZZ	00-99	Last two digits of lot code
Y	0-9	Last digit of year, starting from 2009 (0 for 2010, 1 for 2011, etc)
WW	01-53	Work week

**Figure 20. Tape and Reel Specifications**  
12-lead 2 x 2 x 0.55 mm QFN



-----> Tape Feed Direction ----->



Device Orientation in Tape

**Table 10. Ordering Information**

Order Code	Package	Description	Shipping Method
PE621020MLAA-Z	12-lead 2 x 2 x 0.55 mm QFN	Package Part in Tape and Reel	3,000 units / T&R
EK621020-11	Evaluation Kit	Evaluation Kit	1 set / box

**Sales Contact and Information**

For sales and contact information please visit [www.psemi.com](http://www.psemi.com).

**Advance Information:** The product is in a formative or design stage. The datasheet contains design target specifications for product development. Specifications and features may change in any manner without notice.  
**Preliminary Specification:** The datasheet contains preliminary data. Additional data may be added at a later date. Peregrine reserves the right to change specifications at any time without notice in order to supply the best possible product.  
**Product Specification:** The datasheet contains final data. In the event Peregrine decides to change the specifications, Peregrine will notify customers of the intended changes by issuing a CNF (Customer Notification Form).  
 The information in this datasheet is believed to be reliable. However, Peregrine assumes no liability for the use of this information. Use shall be entirely at the user's own risk.

No patent rights or licenses to any circuits described in this datasheet are implied or granted to any third party. Peregrine's products are not designed or intended for use in devices or systems intended for surgical implant, or in other applications intended to support or sustain life, or in any application in which the failure of the Peregrine product could create a situation in which personal injury or death might occur. Peregrine assumes no liability for damages, including consequential or incidental damages, arising out of the use of its products in such applications.  
 The Peregrine name, logo, UltraCMOS and UTSi are registered trademarks and HaRP, MultiSwitch and DuNE are trademarks of Peregrine Semiconductor Corp.